

Ana Şanzıman Modeli

MERCEDES

G 131-9

G 141-9

G 211-12

G 211-16

G 221-9

G 230-12

G 230-16

G 240-16

G 260-16

G 280-16

G 281-12

G 330-12

PTO'nun Teknik Özellikleri

Kodu 243AC2F

Dişli Tipi Helis

Tipi Çift Dişli / Keçeli

Tork Nm 425

Güç Kw 43

Tahvil Oranı 1000 d/d 1:1,16

Bağlantı Yeri Kuyruktan

Kontrol Sistemi Havalı

PTO Mil Dönüş Yönü Sola (Saatin Aksî Yönü)

Pompa Mil Dönüş Yönü Sağa (Saat Yönü)

Ağırlık Kg. 20,00

Ürün Kod Detayı

2 4 3 A C 2 F

Kardan Mili  
Kare Flanşlı / ISO 14 / DIN 5462 / 8x32x36  
Akuple  
Havalı  
Sıra No

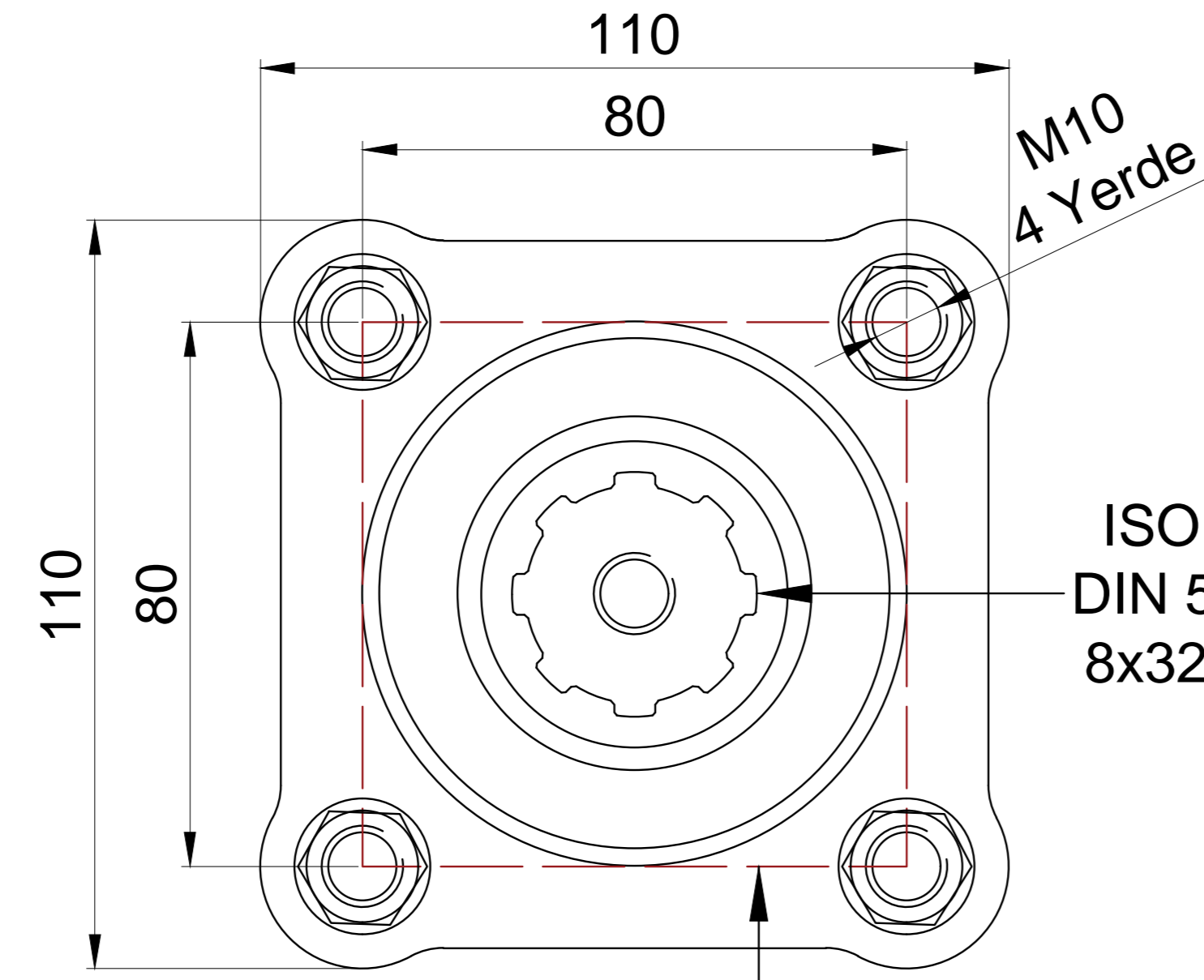

ISO 14  
DIN 5462  
8x32x36

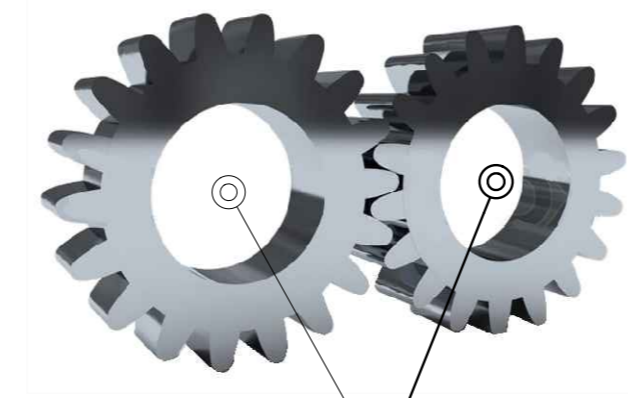

PTO Tipi  
Çift Dişli

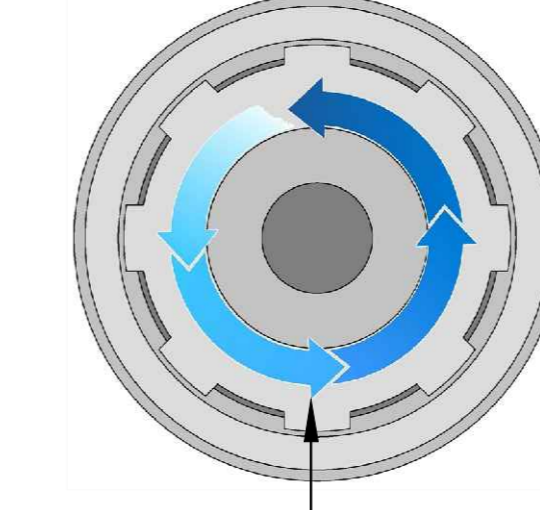

PTO  
Mil Dönüş Yönü  
Sola  
(Saatin Aksî Yönü)

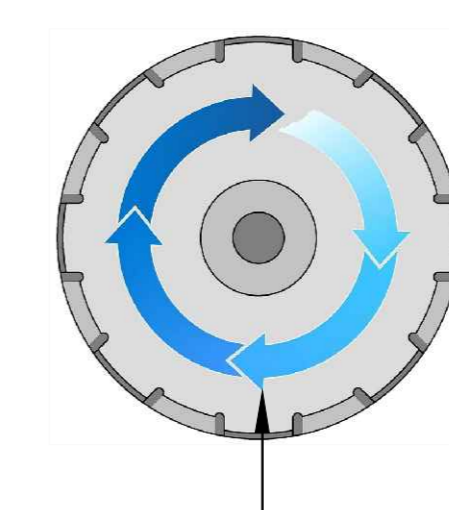

Pompa  
Mil Dönüş Yönü  
Sağa  
(Saat Yönü)



Hava Hortum Girişi R 1/4

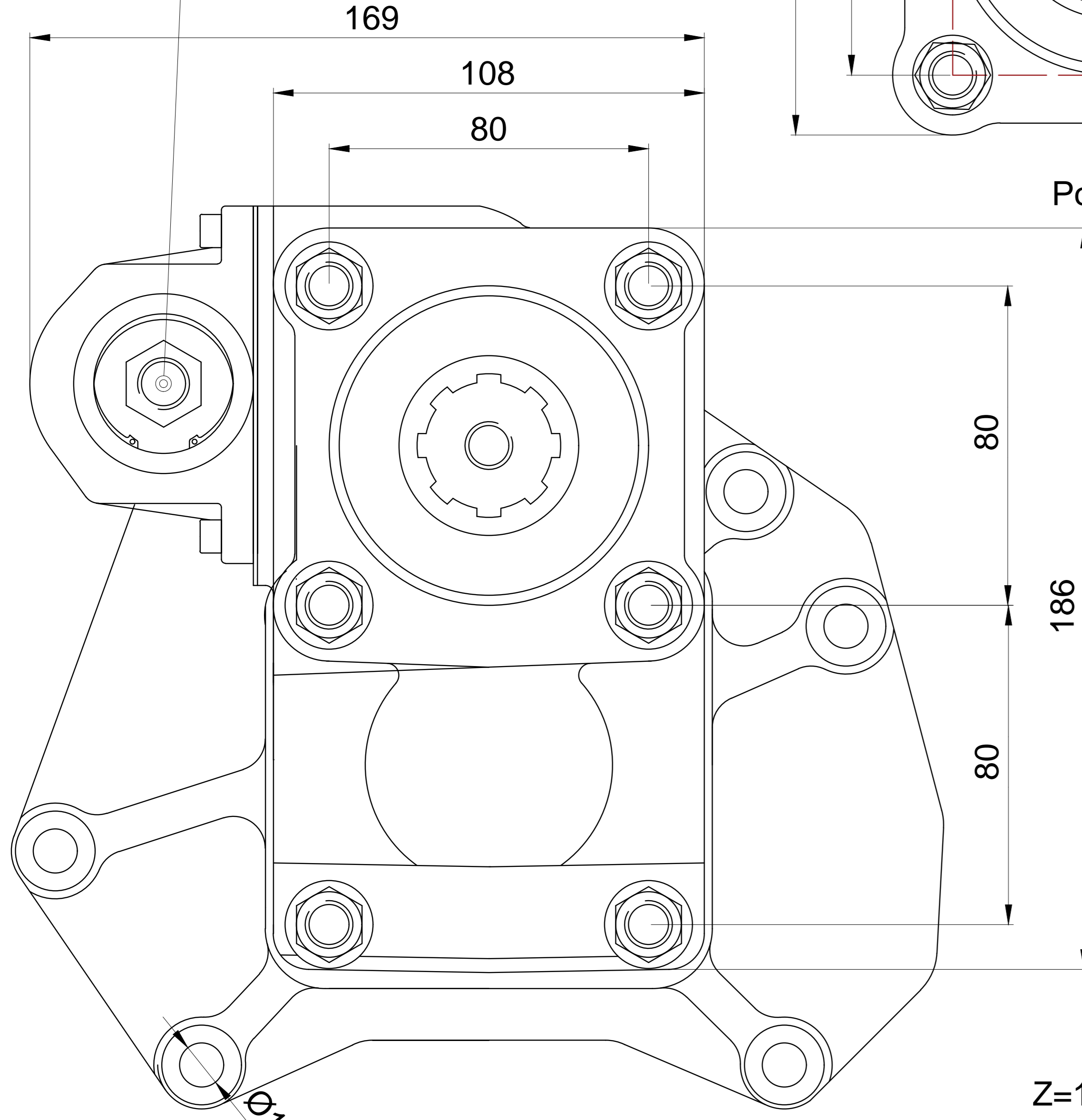

Pompa Bağlantısı  
Kare Flanş

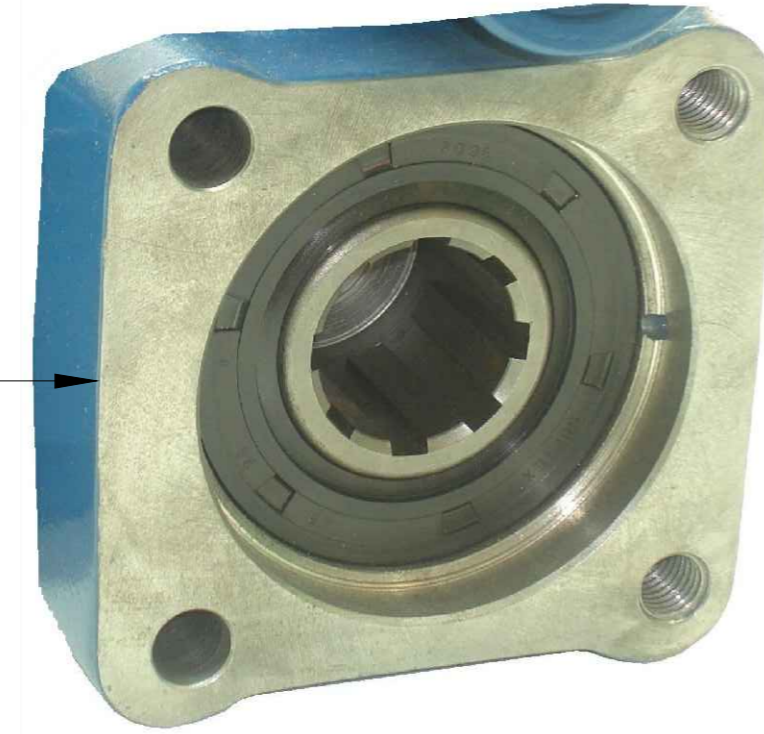

Z=16

K191A022  
Kardan Mili



252

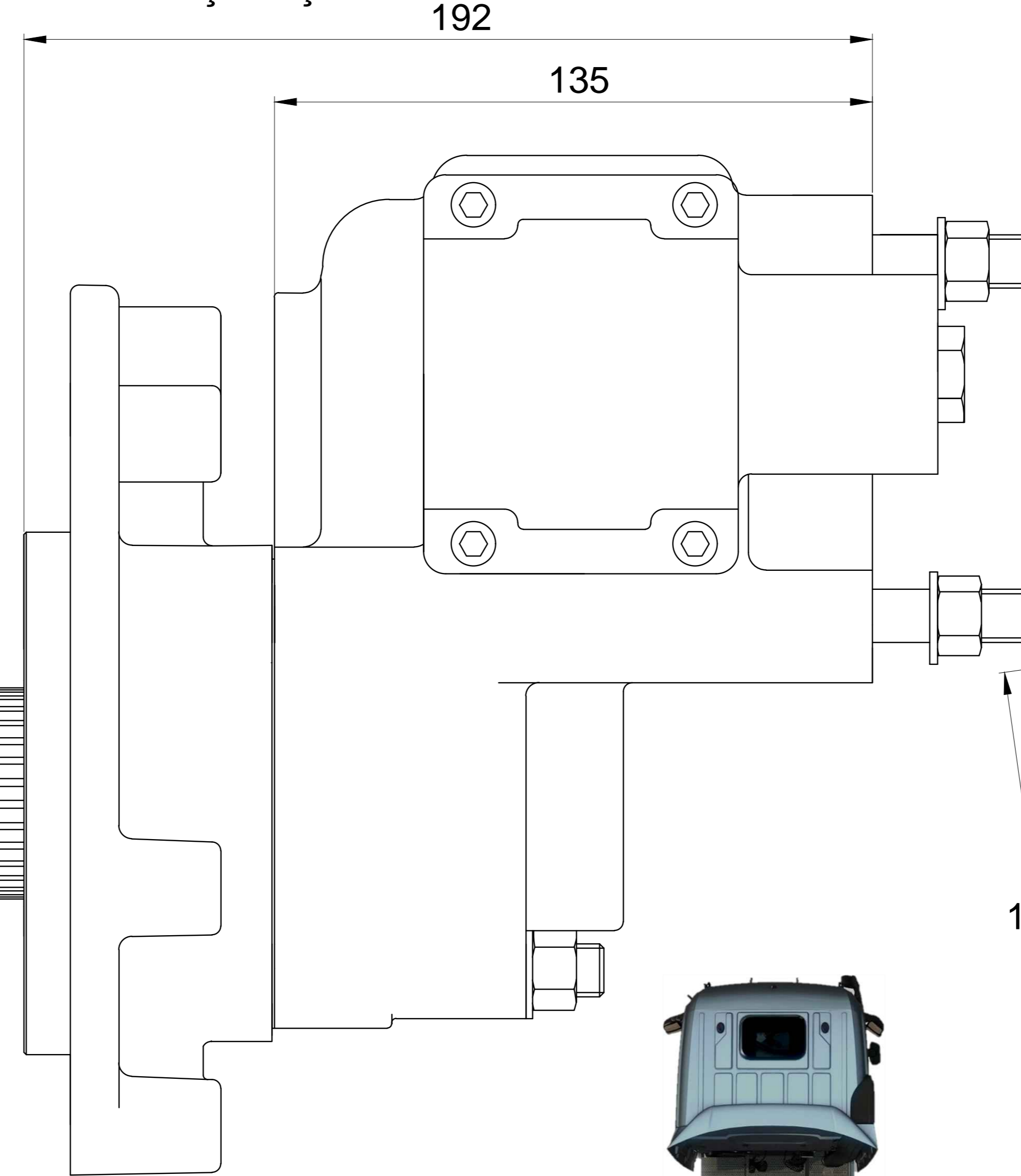

M12

40.21

42

111



PTO  
Bağlantı Yeri  
Aracın Arka Tarafı  
(Kuyruktan)

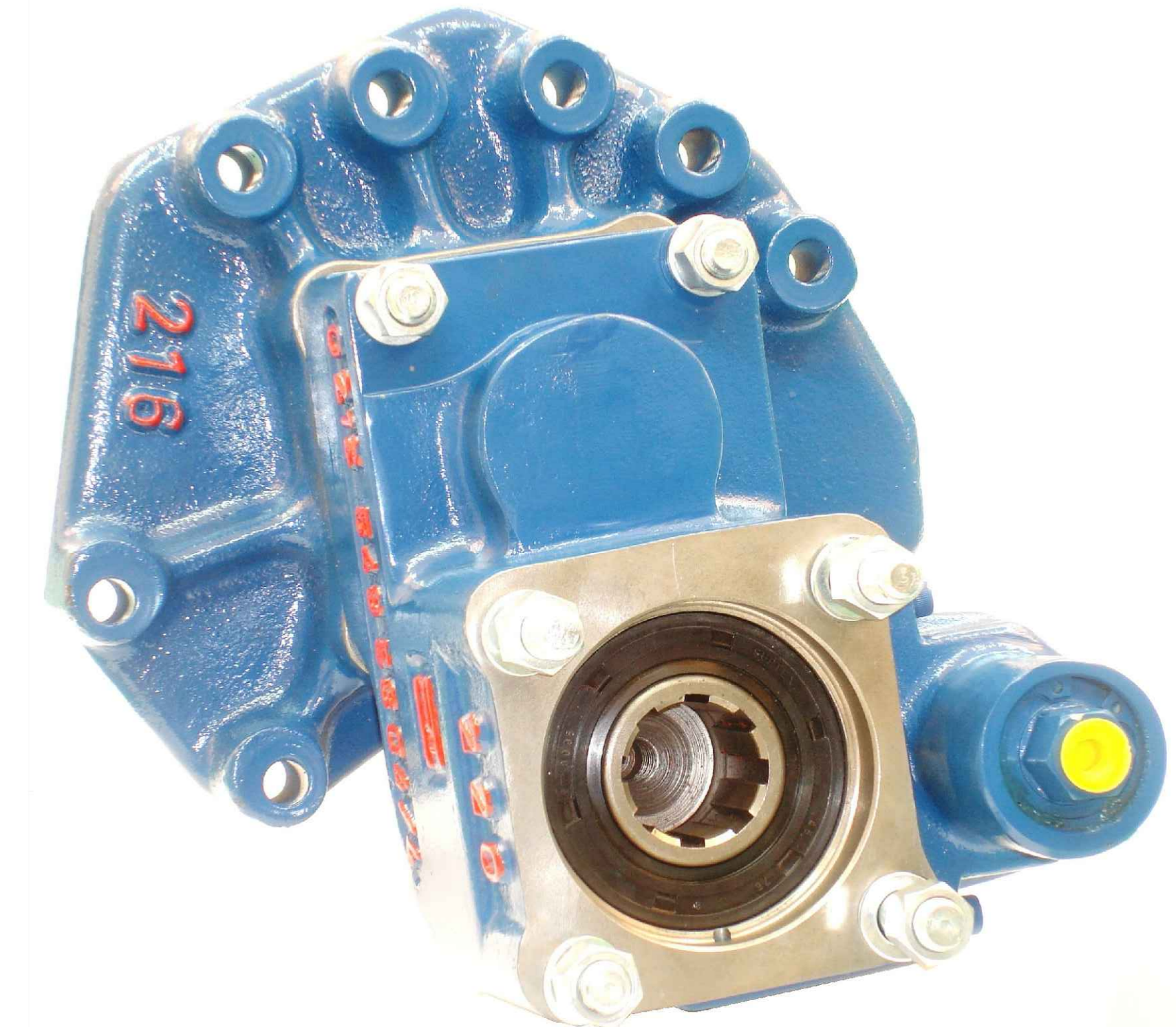
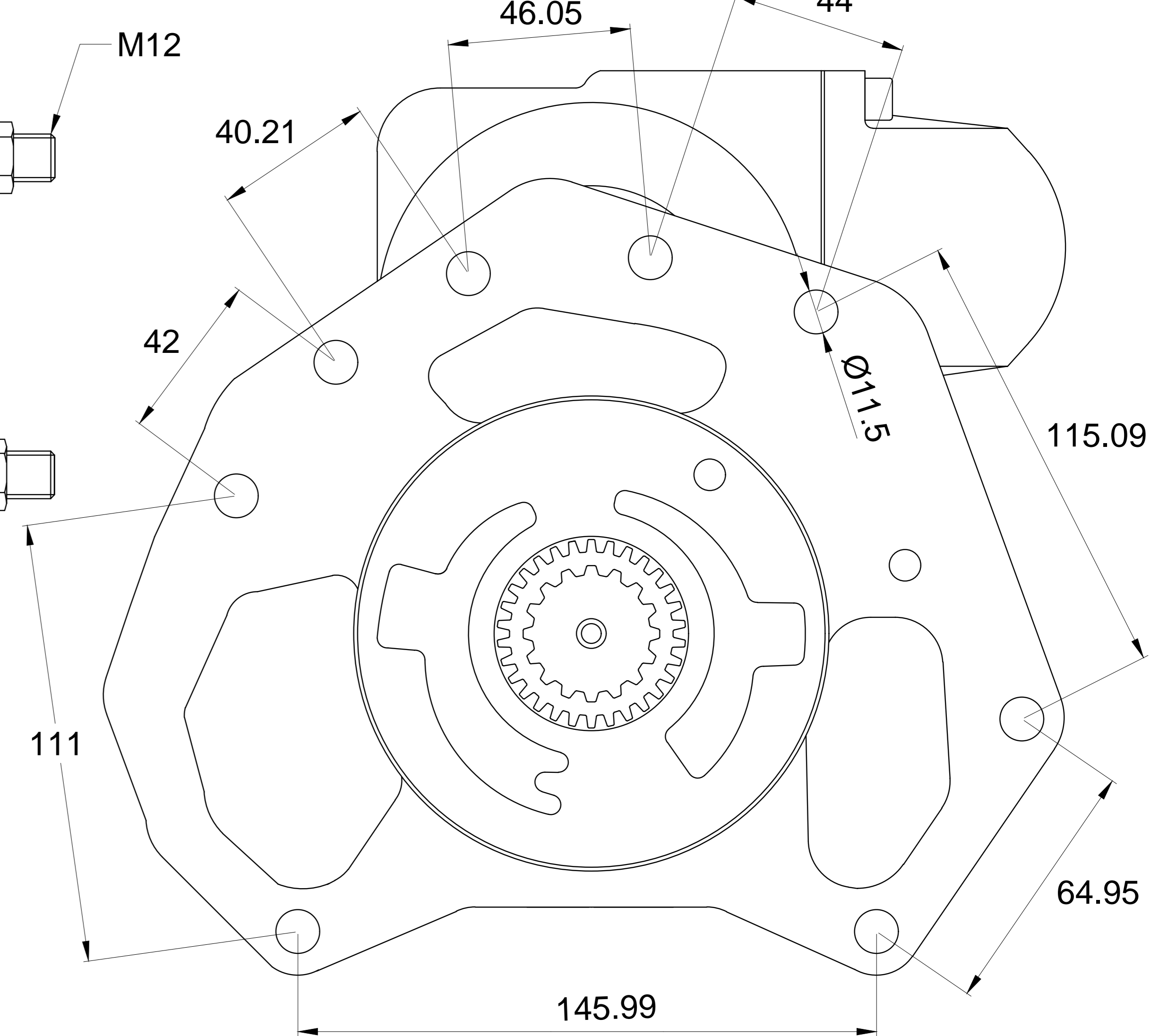

www.pto.com.tr  
info@pto.com.tr

+90 212 549 53 04 Pbx  
+90 212 549 53 08 - 09  
+90 533 960 33 60  
+90 532 554 16 36  
ptomms  
Pto Murat Makine+  
@PTOMURATMAKINA  
+İkitelli Org.San.Bölg. Atatürk Bulv. Eskoop San.Sit. A2. Blok No.80 Başakşehir - İstanbul / TÜRKİYE